



peri com.

atop
Technologies

Serial and Wireless Solutions

Product Selection Guide

Wireless Connectivity
Serial Device Servers
Embedded Computers
Modbus Gateways
Protocol Gateways

2023/2024



Wireless Connectivity

Connectivity for seamless Wi-Fi mesh communication and mobile 4G/5G high-performance throughput

————— *page 4*

Secure internal links and provide cloud service through mobile 4G/5G connectivity.

Serial Device Servers

Communicate with legacy devices leveraging your Ethernet-based network

————— *page 6*

Enable transparent conversion between Serial and Ethernet traffic.

Edge Computers (SDK)

Leverage ATOP's rugged industrial hardware to run your applications

————— *page 10*

Our SDK edge computers come with easy programmable systems and cloud connectivity. A few highlights are:

- ATOP's customized **Linux OS**
- ATOP's **custom APIs and utilities** to control hardware with a wide variety of programming solutions
- An integrated **Building Block programming environment**, in addition to C programming. The environment includes a wide range of customized APIs, allowing you to access hardware through a visual programming environment.

To learn more about our edge computing, check out our Embedded Computing Brochure.



Modbus Gateways

Seamlessly convert or concentrate Modbus RTU/ASCII data to Modbus TCP and greatly increase application performance

————— page 12

Modbus gateways achieve interoperability between Modbus devices and Ethernet-based management, while Modbus concentrators allow faster Modbus polling responsiveness, redundancy, and register remapping.

Protocol Gateways for Smart Grid and Substations

Use ATOP to integrate legacy substation devices into newer networks, or vice-versa

————— page 16

For advanced protocol conversion applications, such as Substation and Industrial scenarios.





Wireless Connectivity









Wireless connections allow for more flexibility and mobility than wired networks, covering large areas and environments where running cables is impractical or impossible—e.g., wide-range or hazardous industrial sites, or mobile AGV/AMR systems. Wireless networking systems are also cost-effective over the long term, as they require less maintenance and can be easily scaled up or down as needed.

ATOP's growing range of wireless solutions bring to you state-of-the-art technology like 5G, mmWave, and WiFi mesh, combined with industry-specific features like PROFINET, PoE, and rugged hardware.

Wireless Routers and Access Points

	Wireless Router			Wireless Access Point/Client		
						
General Information			Coming soon			Coming soon
Model Number	AWR5805	CWR5805	SCN5802	AW5500	AW5500C	AW5601
Network Interfaces						
Total number of WAN ports	1	1	-	-	-	-
10/100 BaseT(X)	-	-	-	-	-	-
10/100/1000 BaseT(X)	1	1	-	-	-	-
Total number of LAN ports	4	4	2	1	1	1
10/100 BaseT(X)	-	-	-	-	1	-
10/100/1000 BaseT(X)	4	4	1	1	-	1
10/100/1000/2500 Base-T	-	-	1	-	-	-
Wireless LAN	802.11 a/b/g/n/ac	802.11 a/b/g/n/ac	802.11 a/ac	802.11 a/b/g/n	802.11 b/g/n	802.11 a/b/g/n/ac
Mobile interfaces	-	4G/5G (Sub-6)	4G/5G (mmWave/Sub-6)	-	-	-
Power supply input						
Low voltage DC power input	12-48 VDC	12-48 VDC	12-57VDC	9-48 VDC	9-48 VDC	12-48 VDC
Power through PoE	Optional (802.3af)	Optional (802.3af)	Optional (802.3bt)			Optional (802.3af)
Power inputs	1	1	1	1	1	1
Relay output						
Installation Option						
DIN-Rail Mount	•	•		•	•	•
19" Rack Mount						
Field Mount	•	•	•	•	•	•
Mobile Wireless Router						
4G/5G mobile connectivity		•	•			
Dual-SIM Backup		•				
Firewall	•	•	•	•	•	•
VPN	•	•	•			
Wi-Fi Mesh Connectivity	•	•	•			
Mobile Ether WAN backup/failover		•				
Compliance						
Industrial EMC Protection	•	•	•	•	•	•
UL60950-1 and/or UL62368	•	•	Optional	•	•	•
UL61010-2-201						
EN60950-1 and/or EN62368	•	•	Optional	•	•	•
CE (EN61000-6-2 and EN61000-6-4)	•	•	Optional			
RED (Radio Directive 2014/53/EU)	•	•	Optional	•	•	•
FCC Part 15 Subpart B Class A	•	•	Optional	•	•	•

Wireless Interoperability

	Serial Device Servers				Modbus Gateways			Protocol Gateways*	
	Wi-Fi	Wi-Fi	NB-IoT / LTE Cat 1	LTE Cat 4	Wi-Fi	NB-IoT / LTE Cat 1	LTE Cat 4	NB-IoT / LTE Cat 1	LTE Cat 4
									
General Information			NEW!			Coming soon		Coming soon	
Model Number	SW5501/2	SW5501/2C	SE5201B	SE5901B	MW5501/2C	MB5201B	MB5901B	PG5201B	PG5901B
Network Features									
Total number of ports	1	1	2	1	1	2	1	2	1
Total Fast Ethernet	-	1	2	-	1	2	-	2	-
10/100 BaseT(X)	-	1	2	-	1	2	-	2	-
100 Base-X (SFP)	-	-	-	-	-	-	-	-	-
Total Gigabit	1	-	-	1	-	-	1	-	1
10/100/1000 BaseT(X)	1	-	-	1	-	-	1	-	1
100/1000 Base-X SFP	-	-	-	-	-	-	-	-	-
Wi-Fi interface	2.4/5GHz	2.4GHz	-	-	2.4GHz	-	-	-	-
3G/4G interfaces	-	-	•	•	-	•	•	•	•
Number of SIM cards	-	-	Max 2	1	-	Max 2	1	Max 2	1
VPN	-	-	•	•	-	•	•	•	•
Serial Ports									
Number of ports	1/2	1/2	1	1/2 (IO vers)	1/2	1	1/2 (IO vers)	1	1/2 (IO vers)
RS-232 RS-422 RS-485 full func.	1/2	1/2	1	1(RS-232/485)	1/2	1	1(RS-232/485)	1	1(RS-232/485)
RS-232 only	-	-	-	1(only IO vers.)	-	-	1(only IO vers.)	-	1(only IO vers.)
Serial port Isolation	3kV(Optional)	-	-	-	-	-	-	-	-
Serial port connector	DSub9 or TB	DSub9 or TB	DSub9 or TB	DSub9 or TB	DSub9 or TB	DSub9 or TB	DSub9 or TB	DSub9 or TB	DSub9 or TB
Other Interfaces									
Digital Inputs	-	-	1	2 (Optional)	-	1	2 (Optional)	1	2 (Optional)
Digital Outputs	-	-	1	2 (Optional)	-	-	2 (Optional)	1	2 (Optional)
Power Supply Input									
Power Input	9-48 VDC	9-48 VDC	9-48 VDC	9-48 VDC	9-48 VDC	9-48 VDC	9-48 VDC	9-48 VDC	9-48 VDC
Mechanical									
Installation	DIN-Rail	DIN-Rail	DIN-Rail	DIN-Rail	DIN-Rail	Rack-mount	Rack-mount	Rack-mount	Rack-mount
Ingress Protection	IP30	IP30	IP30	IP30	IP30	IP30	IP30	IP30	IP30
Dimensions (L x H x D) in mm	47 x 110 x 90	47 x 110 x 90	30x136x95	32 x 122 x 92	47 x 110 x 90	30 x 136 x 95	32 x 110 x 90	30x136x95	32x122x92
Supported Temperatures									
Operations Temperature	-10°C to +60°C	-10°C to +60°C	-30 to +75°C	-40°C to +70°C	-10°C to +60°C	-30°C to +75°C	-40°C to +70°C	-30 to +75°C	-40 to +70°C
Storage Temperature	-40°C to +85°C	-40°C to +85°C	-40°C to +85°C	-40°C to +85°C	-40°C to +85°C	-40°C to +85°C	-40°C to +85°C	-40°C to +85°C	-40°C to +85°C
Compliance									
Industrial EMC Protection	•	•	•	•	•	•	•	•	•
CE/FCC	•	•	•	•	•	•	•	•	•
UL/EN/IEC(CB)60950-1 and/or 62368-1	•	•	•	•	•	•	•	•	•
EN60950-1 and/or EN62368	•	•	•	•	•	•	•	•	•
Serial Server									
TCP Client (max connections)	2/VCOM	2/VCOM	1	2/VCOM				1	1
TCP Server (max connections)	4/VCOM	4/VCOM	4	4/VCOM				4	4
UDP (ranges)	4	4	8	4				8	8
VirtualCOM	•	•	•	•				•	•
Reverse Telnet	•	•	•	•				•	•
Modbus Features									
Modbus TCP/RTU/ASCII Gateway					•	•	•		•
Modbus TCP/RTU/ASCII Concentrator									
Redundancy option									
Maximum number of slaves					•		•		
Exception error handling					•	•	•		

*See page 20 for software specifications

Serial Device Servers

ATOP's serial-to-Ethernet device servers allow easy connection between RS-232/422/485 legacy devices to Ethernet through wired or wireless means. These devices are specifically designed to allow industrial devices to be accessible from the local network or the Internet. ATOP has serial device servers supporting 1x to 16x serial ports. With wall-mount, DIN-rail mount, or rackmount housing, they enable easy installation and deployment for integrating legacy devices to a modern network.

Entry-level serial servers



Low-cost, hardened hardware solutions for serial server applications in standard operating environments of normal temperature ranges. Provides basic functionalities and semi-industrial EMC protection.

Rugged serial servers



Featuring high-power industrial CPU and high EMC levels (3 to 5 or IEC61850-3), these devices offer excellent performance and scalability for Modbus gateways, Modbus concentrators, protocol gateways. SDK support transforms these servers into embedded computers for unique scenarios and customized functions.





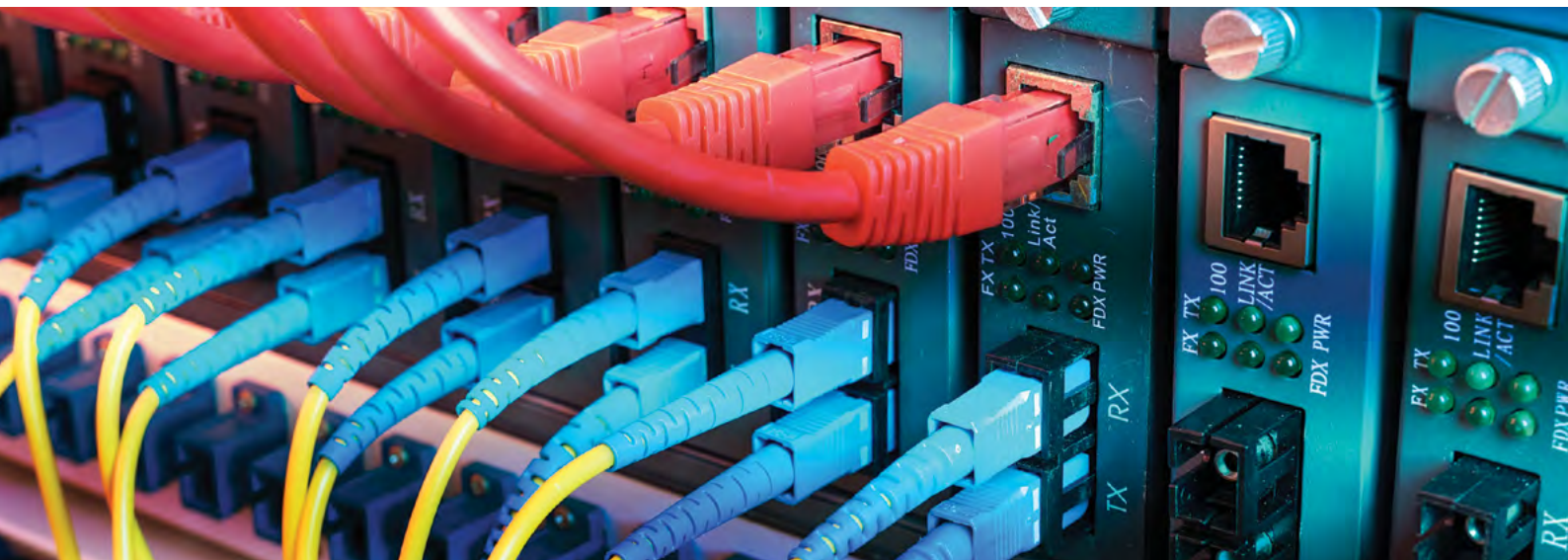

Serial console servers



ATOP serial console servers offer up to 48 serial interfaces in a compact 1U chassis. It is a valuable tool for network administrators to manage and troubleshoot network devices, providing a reliable and secure way to access them remotely.



Serial Device Servers

	Entry-level			Wi-Fi		Cellular	
							
General Information							
Model Number	SE5201C	SE5201	SE5202	SW5501/2	SW5501/2C	SE5201B NEW!	SE5901B
Network Interfaces							
Total number of ports	1	1	1	1	1	1	1
Total Fast Ethernet	1	1	1	-	1	-	-
10/100 BaseT(X)	1	1	(1)*	-	1	-	-
100 Base-X (SFP)	-	-	(1)*	-	-	-	-
Total Gigabit	-	-	-	1	-	1	1
10/100/1000 BaseT(X)	-	-	-	1	-	1	1
100/1000 Base-X SFP	-	-	-	-	-	-	-
Wi-Fi interface	-	-	-	2.4/5GHz	2.4GHz	-	-
4G interfaces	-	-	-	-	-	Cat 1	Cat 4
Network Redundancy							
RSTP redundant ports	-	-	-	-	-	-	-
Serial Ports							
Number of ports	1	1	2	1/2	1/2	1	1/2 (IO vers)
RS-232 RS-422 RS-485 full func.	1	1	2	1/2	1/2	1	1 (RS-232/485)
RS-232 only	-	-	-	-	-	-	1 (only IO vers.)
Serial port Isolation	-	-	3kV (Optional)	3kV (Optional)	-	-	-
Serial port connector	DSub9/TB	DSub9/TB	DSub9/TB	DSub9/TB	DSub9/TB	DSub9/TB	DSub9/TB
Other Interfaces							
Digital Inputs	-	-	-	-	-	1	2 (Optional)
Digital Outputs	-	-	-	-	-	1	2 (Optional)
Relay Output	-	-	-	-	-	-	-
Power Supply Input							
Power Input	5 VDC	5 & 9-30 VDC	5 & 9-30 VDC	9-48 VDC	9-48 VDC	9-48 VDC	9-48 VDC
Power PoE 802.3af (PD)							
AC power input							
High Voltage DC power input							
Power Redundancy		•	•				
Mechanical							
Installation	Field-Mount	Field-Mount	Field-Mount	DIN-Rail	DIN-Rail	DIN-Rail	DIN-Rail
Ingress Protection	IP30	IP30	IP30	IP30	IP30	IP30	IP30
Dimensions (L x H x D) in mm	65 x 78 x 28	65 x 78 x 28	75 x 85 x 28	47 x 110 x 90	47 x 110 x 90	30 x 136 x 95	32 x 110 x 90
Supported Temperatures							
Operations Temperature	-40°C to +70°C	-40°C to +70°C	-40°C to +70°C	-10°C to +60°C	-10°C to +60°C	-30°C to +75°C	-40°C to +70°C
Storage Temperature	-40°C to +85°C	-40°C to +85°C	-40°C to +85°C	-40°C to +85°C	-40°C to +85°C	-40°C to +85°C	-40°C to +85°C
Serial Server							
TCP Client (max connections)	1/VCOM	1/VCOM	1/VCOM	2/VCOM	2/VCOM	1/VCOM	2/VCOM
TCP Server (max connections)	4	4	4	4/VCOM	4/VCOM	4/VCOM	4/VCOM
UDP (ranges)	4	4	4	4	4	8	4
VirtualCOM	•	•	•	•	•	•	•
Reverse Telnet	•	•	•	•	•	•	•
VPN				•	•	•	•
Compliance							
Industrial EMC Protection		•	•	•	•	•	•
CE/FCC	•	•	•	•	•	•	•
UL/EN/IEC(CB)60950-1 and/or 62368-1				•	•	•	•
EN60950-1 and/or EN62368	•	•	•	•	•	•	•
UL61010-2-201							
EN50155 / EN50121-4							
IEC61850-3 / IEEE1613							

*Numbers in parenthesis are options

Serial Device Servers

Rugged



General Information

Model Number	SE5901	SE5904D	SE5908	SE5916	SE5908A	SE5916A	SE8502
--------------	--------	---------	--------	--------	---------	---------	--------

Network Interfaces

Total number of ports	2	2	2	2	6	6	1
Total Fast Ethernet	2	(2)*	2	2	6	6	1
10/100 BaseT(X)	2	(2)*	2	2	(6)*	(6)*	1 (M12)
100 Base-X (SFP)	-	-	-	-	(6)*	(6)*	-
Total Gigabit	-	(2)*	-	-	-	-	-
10/100/1000 BaseT(X)	-	-	-	-	-	-	-
100/1000 Base-X SFP	-	(2)*	-	-	-	-	-
Wi-Fi interface	-	-	-	-	-	-	-
3G/4G interfaces	-	-	-	-	-	-	-

Network Redundancy

RSTP redundant ports	2	2	2	2	2	2	-
----------------------	---	---	---	---	---	---	---

Serial Ports

Number of ports	1	4	8	16	8	16	2 (M12)
RS-232 RS-422 RS-485 full func.	1	4	8	16	8	16	2 (M12)
RS-232 only	-	-	-	-	-	-	-
Serial port Isolation	-	3kV (Optional)	2.5kV (Optional)	2.5kV (Optional)	3kV (Optional)	3kV (Optional)	-
Serial port connector	DSub9/TB	DSub9/TB	RJ45	RJ45	DSub9/TB	DSub9/TB	M12

Other Interfaces

Digital Inputs	-	-	-	-	-	-	2 (Optional)
Digital Outputs	-	-	-	-	-	-	2 (Optional)
Relay Output	-	1	-	-	2	2	-

Power Supply Input

Power Input	9-48 VDC	12-48 VDC	24-48 VDC	24-48 VDC	24-48 VDC	24-48 VDC	9-48 VDC
Power PoE 802.3af (PD)	By request	By request					
AC power input			100-240VAC	100-240VAC	100-240VAC	100-240VAC	
High Voltage DC power input					100-370VDC	100-370VDC	
Power Redundancy	•	•			•	•	

Mechanical

Installation	DIN-Rail	DIN-Rail	Rack-mount	Rack-mount	Rack-mount	Rack-mount	Field-Mount
Ingress Protection	IP30	IP30	IP30	IP30	IP30	IP30	IP68
Dimensions (L x H x D) in mm	32 x 122 x 92	55 x 145 x 113	440 x 44 x 200	440 x 44 x 200	440 x 44 x 309	440 x 44 x 309	80 x 145 x 24

Supported Temperatures

Operations Temperature	-40°C to +85°C	-40°C to +85°C	-20°C to +70°C	-20°C to +70°C	-40°C to +85°C	-40°C to +85°C	-40°C to +75°C
Storage Temperature	-40°C to +85°C	-40°C to +85°C	-40°C to +85°C	-40°C to +85°C	-40°C to +85°C	-40°C to +85°C	-40°C to +85°C

Serial Server

TCP Client (max connections)	2/VCOM	2/VCOM	2/VCOM	2/VCOM	2/VCOM	2/VCOM	2/VCOM
TCP Server (max connections)	4/VCOM	4/VCOM	4/VCOM	4/VCOM	4/VCOM	4/VCOM	4/VCOM
UDP (ranges)	4	4	4	4	4	4	4
VirtualCOM	•	•	•	•	•	•	•
Reverse Telnet	•	•	•	•	•	•	•
VPN	•	•	•	•	•	•	•

Compliance

Industrial EMC Protection	•	•	•	•	•	•	•
CE/FCC	•	•	•	•	•	•	•
UL/EN/IEC(CB)60950-1 and/or 62368-1							
EN60950-1 and/or EN62368	•	•	•	•	•	•	•
UL61010-2-201		•					
EN50155 / EN50121-4							•
IEC61850-3 / IEEE1613					•	•	

*Numbers in parenthesis are options

Serial Console Servers



	VSE5908	VSE5916	VSE5932	VSE5948
General Information				
Model Number	VSE5908	VSE5916	VSE5932	VSE5948
Network Interfaces				
Total number of ports	4	4	4	4
Total Gigabit	4	4	4	4
10/100/1000 BaseT(X)	2	2	2	2
100/1000 Base-X SFP	2	2	2	2
Network Redundancy				
RSTP redundant ports	2	2	2	-
Serial Ports				
Number of ports	8	16	32	48
RS-232 full func.	•	•	•	•
Serial port connector(RJ45)	8	16	32	48
Other Interfaces				
Digital Inputs	-	-	-	2 (Optional)
Digital Outputs	-	-	-	2 (Optional)
Relay Output	-	-	2	-
Power Supply Input				
AC power input	100-240VAC	100-240VAC	100-240VAC	100-240VAC
High Voltage DC power input	-	-	-	-
Power Redundancy	-	-	-	-
Hardware Specifications				
Installation	1U Rackmount	1U Rackmount	1U Rackmount	1U Rackmount
Dimensions (L x H x D) in mm	440 x 44 x 284.2	440 x 44 x 284.2	440 x 44 x 284.2	440 x 44 x 284.2
Supported Temperatures				
Operations Temperature	5°C to 50°C	5°C to 50°C	5°C to 50°C	5°C to 50°C
Storage Temperature	-30°C to 60°C	-30°C to 60°C	-30°C to 60°C	-30°C to 60°C
Security				
SSH/SSL/HTTPS	•	•	•	•
RADIUS/TACACS+	•	•	•	•
ICMP, TCP, UDP, IPv4 and IPv6, ARP	•	•	•	•
SNMP v1/v2/v3	•	•	•	•
Compliance				
Industrial EMC Protection	•	•	•	•
CE/FCC	•	•	•	•

Edge Computers with Software Development Kit (SDK)

Standard ATOP serial servers provide functions for most common applications, but communication, security, data filter, or other reasons may create unique scenarios and thus the need for proprietary apps.

To enable functions that are not built in on standard devices, ATOP supplies an SDK for developers to create software applications on a specified platform.

Software Architecture of ATOP SDK

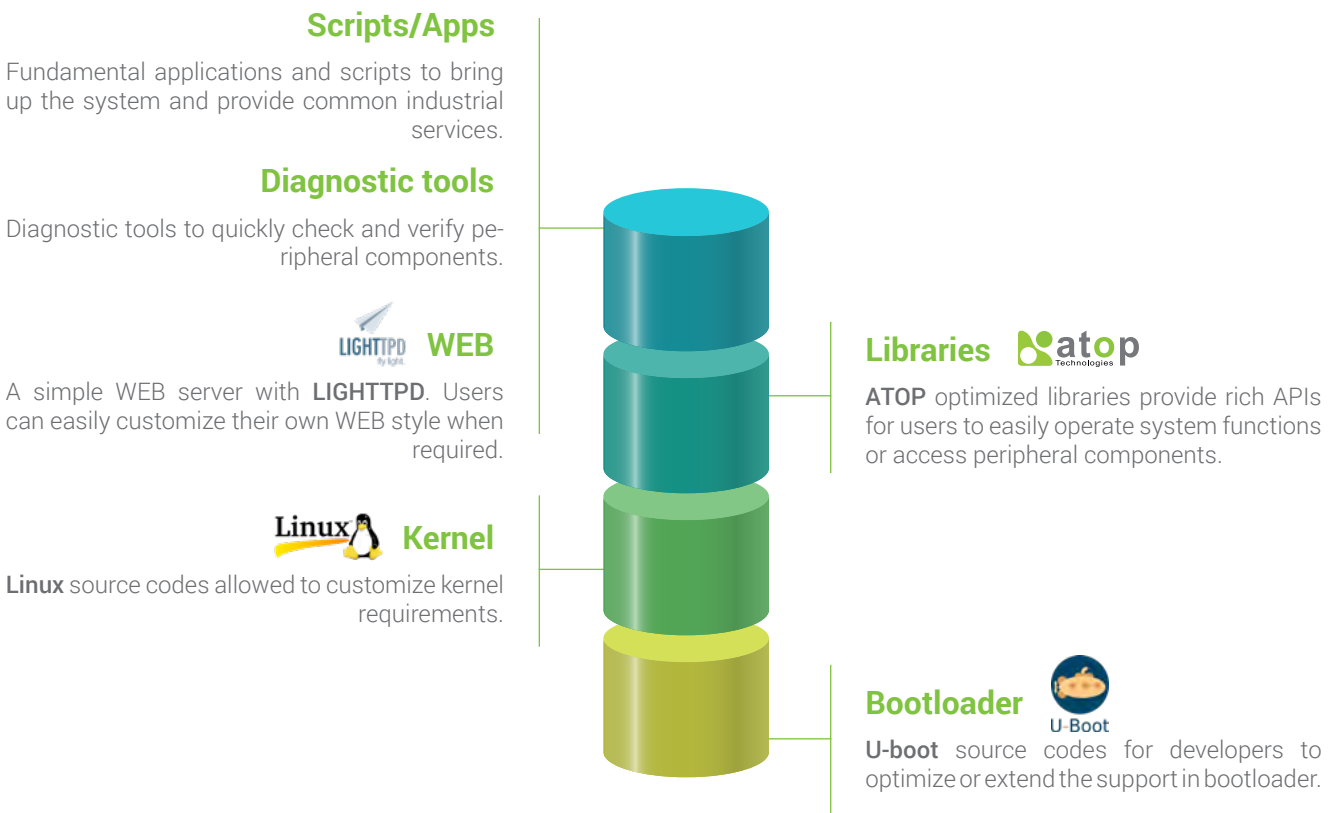

How to use ATOP SDK?

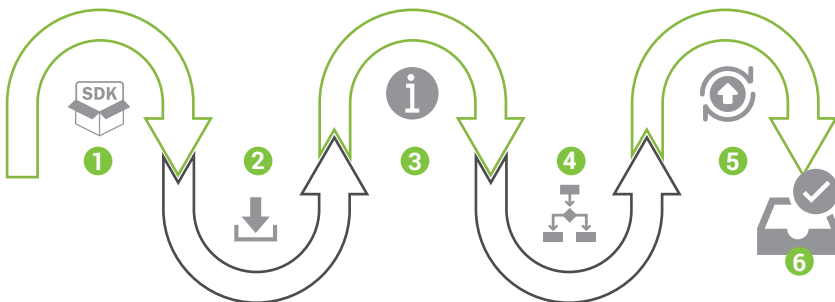

1. Get SDK from your ATOP representative
2. Install the toolchain and source package to the developing environment
3. Follow user/programming guide to develop applications
4. Compile and generate image with SDK
5. Upgrade image/apps to platform
6. Enjoy the new image/apps on the platform

Edge Computers



General Information

Model Number	SE5901-sdk	SE5901B-sdk	SE5904D-sdk	SE5908-sdk	SE5916-sdk	SE5908A/16A-sdk
--------------	------------	-------------	-------------	------------	------------	-----------------

Network Interfaces

Total number of ports	2	1	2	2	2	6
Total Fast Ethernet	2	-	(2)*	2	2	6
10/100 BaseT(X)	2	-	(2)*	2	2	(6)*
100 Base-X (SFP)	-	-	-	-	-	(6)*
Total Gigabit	-	1	(2)*	-	-	-
10/100/1000 BaseT(X)	-	1	-	-	-	-
100/1000 Base-X SFP	-	-	(2)*	-	-	-
3G/4G interfaces	-	•	-	-	-	-

Serial Ports

Number of ports	1	1/2 (IO vers)	4	8	16	8/16
RS-232 RS-422 RS-485 full func.	1	1 (RS-232/485)	4	8	16	8/16
RS-232 only	-	1 (only IO vers.)	-	-	-	-
Serial port Isolation	-	-	3kV (Optional)	2.5kV (Optional)	2.5kV (Optional)	3kV (Optional)
Serial port connector	DSub9 or TB	DSub9 or TB	DSub9 or TB	RJ45	RJ45	DSub9 or TB

Hardware Specifications

CPU Architecture	ARM	ARM	ARM	ARM	ARM	ARM
CPU Speed	800MHz	800MHz	800MHz	800MHz	800MHz	1000MHz
RAM	256MB (Max)	256MB (Max)	512MB (Max)	512MB (Max)	512MB (Max)	512MB (Max)
Flash	128MB (Max)	128MB (Max)	128MB (Max)	128MB (Max)	128MB (Max)	128MB (Max)
Hardware Watchdog	•	•	•	•	•	•
Buzzer	•	•	•	•	•	•
Digital Inputs		2 (Optional)				
Digital Outputs		2 (Optional)				
Relay Output			1			2
USB	2	2	1			
SD or MicroSD cards slot		•	•	•	•	•

Power Supply Input

Power Input	9-48 VDC	9-48 VDC	12-48 VDC	24-48 VDC	24-48 VDC	24-48 VDC
Power PoE 802.3af (PD)	Optional		Optional			
AC power input				100-240VAC	100-240VAC	100-240VAC
High Voltage DC power input						100-370VDC
Power Redundancy			•			•

Mechanical

Installation	DIN-Rail	DIN-Rail	DIN-Rail	Rack-mount	Rack-mount	Rack-mount
Ingress Protection	IP30	IP30	IP30	IP30	IP30	IP30
Dimensions (L x H x D) in mm	TBD	TBD	TBD	440 x 44 x 200	440 x 44 x 200	440 x 44 x 309

Supported Temperatures

Operations Temperature	-40°C to +85°C	-40°C to +70°C	-40°C to +85°C	-20°C to +70°C	-20°C to +70°C	-40°C to +85°C
Storage Temperature	-40°C to +85°C	-40°C to +85°C	-40°C to +85°C	-40°C to +85°C	-40°C to +85°C	-40°C to +85°C

Compliance

Industrial EMC Protection	•	•	•	•	•	•
CE/FCC	•	•	•	•	•	•
UL/EN/IEC(CB)60950-1 and/or 62368-1		•				
EN60950-1 and/or EN62368	•	•	•	•	•	•
UL61010-2-201			•			
EN50155 / EN50121-4						
IEC61850-3 / IEEE1613						•

*Numbers in parenthesis are options

Modbus Gateways

Modbus is a communication protocol commonly used in industrial automation, substations, and building automation systems. A serial communication protocol that was developed in 1979, it has since become an industry standard. Its Ethernet version, Modbus TCP, is useful for integrating legacy Modbus devices into newer, more modern systems.

A Modbus gateway acts as a translator between Modbus Serial and Modbus TCP, allowing the serial data to transfer through wider areas, in faster speeds, and even wireless media to enable state-of-the-art control, monitoring, and analysis, while minimizing costs for equipment renewal.

Entry level - Modbus gateway

FEATURES

- Low-cost, easy to apply.
- Seamlessly provides conversion between Ethernet-based Modbus TCP and serial-based Modbus RTU/ASCII.
- Suitable for periodic data polling.

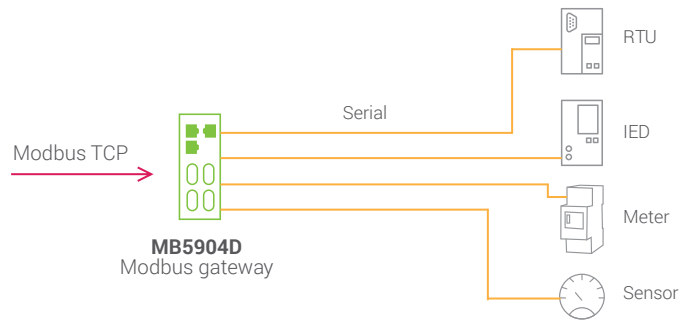

Advanced - Concentrator

FEATURES

- Suitable for frequent polling requests from multiple devices.
- Allows data to be polled automatically from slave devices. Data will be available for master polling at all times.
- Faster responsiveness, removing the risk of Modbus TCP timeouts.
- Customizable register mapping for optimal performance where different masters need to access different data structures.
- Supports link status and data timestamp access.

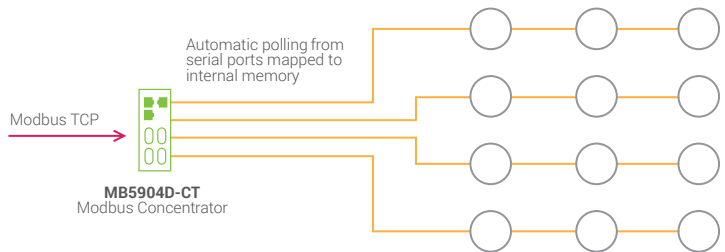

Top of the line - Redundant concentrator

FEATURES

- Redundant architecture for the most mission critical applications. Automatic link recovery in case of Ethernet or Serial link failure.
- Supports link status and data timestamp access.

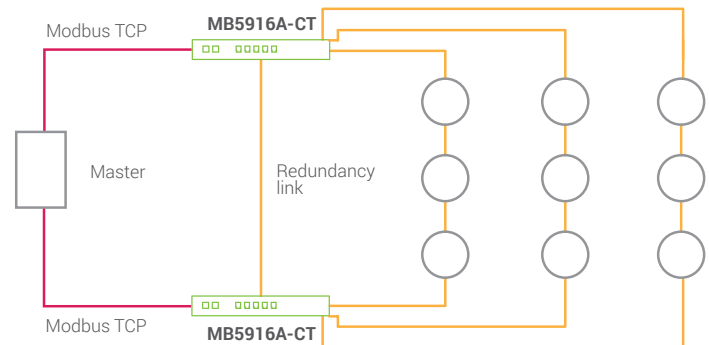

Automatic polling from serial ports with link failure recovery mechanism.

Modbus Redundant Concentrator Success Story



Managing substation infrastructure with Modbus TCP SCADA

Challenge: To manage, through a Modbus TCP SCADA, a large low-voltage substation infrastructure that is Modbus RTU-based. The complex infrastructure involves switchboards with around 190 slaves each, and accessing all slaves simultaneously for data, diagnostics, and configuration. Poll commands must be executed within 600 ms, and the whole system integrated with the client's own device management tool.

Location: Malaysia, Petrochemical and Refinery Complex

Protocol used: Modbus TCP/Modbus RTU

Requirements: Short failure recovery time; very efficient Modbus polling in an environment with a high density of devices.

Solution provided

- Modbus redundant concentrators designed and set up in pairs, with redundancy fiber link in between and COM links that connect from one device to the other.
- Optimized software for command priority to ensure execution time.
- Managed Ethernet switches providing the backbone to the customer's EWS.

Results achieved

- 600 ms complete polling for more than 100 slaves, each with 20 registers (19200 bps).
- 500 ms secondary recovery to handle primary device downtime or device failure.
- Multi-write command to map different slaves simultaneously and improve efficiency.

Network Topology

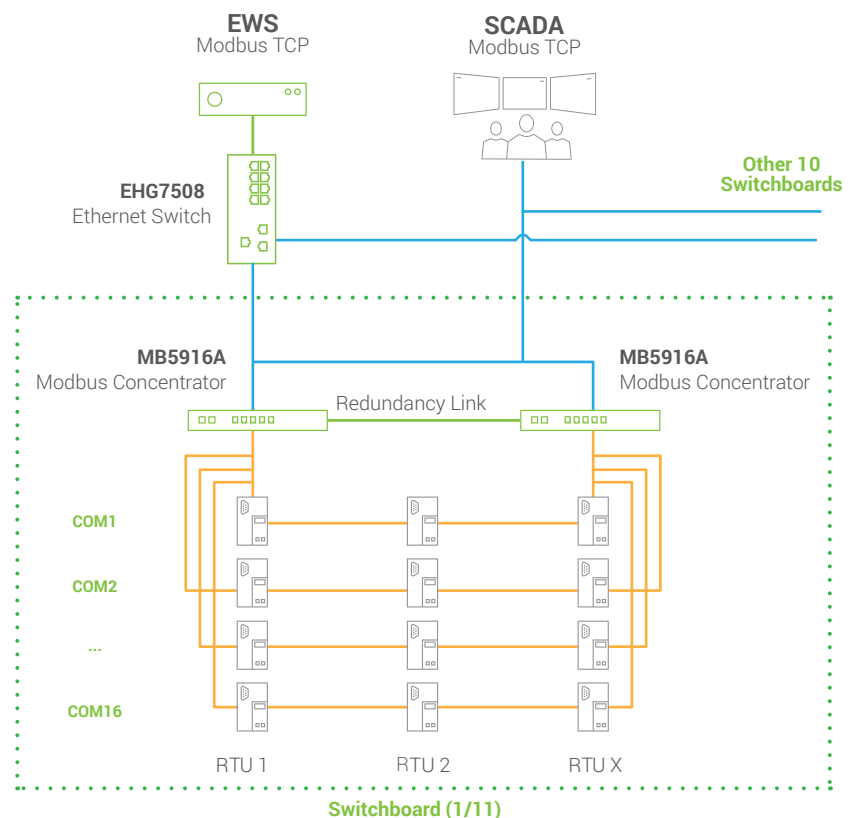

Modbus Gateways

	Entry-level		Wi-Fi	Cellular	
					
General Information				Coming soon	
Model Number	MB5201	MB5202	MW5501/2C	MB5201B	MB5901B
Network Interfaces					
Total number of ports	1	1	1	2	1
Total Fast Ethernet	1	1	1	2	-
10/100 BaseT(X)	1	1	1	2	-
100 Base-X (SFP)	-	-	-	-	-
Total Gigabit	-	-	-	-	1
10/100/1000 BaseT(X)	-	-	-	-	1
100/1000 Base-X SFP	-	-	-	-	-
Wi-Fi interface	-	-	2.4GHz	-	-
4G interfaces	-	-	-	Cat 1	Cat 4
Network Redundancy					
RSTP redundant ports	-	-	-	-	-
Serial Ports					
Number of ports	1	2	1/2	1	1/2 (IO vers)
RS-232 RS-422 RS-485 full func.	1	2	1/2	1	1 (RS-232/485)
RS-232 only	-	-	-	-	1 (only IO vers.)
Serial port Isolation	-	3kV(Optional)	-	-	-
Serial port connector	DSub9/TB	DSub9/TB	DSub9/TB	DSub9/TB	DSub9/TB
Other Interfaces					
Digital Inputs	-	-	-	1	2 (Optional)
Digital Outputs	-	-	-	-	2 (Optional)
Relay Output	-	-	-	1	-
Power Supply Input					
Power Input	5 & 9-30 VDC	5 & 9-30 VDC	9-48 VDC	9-48 VDC	9-48 VDCC
Power PoE 802.3af (PD)					
AC power input					
High Voltage DC power input					
Power Redundancy	•	•			
Mechanical					
Installation	Field-Mount	Field-Mount	DIN-Rail	DIN-Rail	DIN-Rail
Ingress Protection	IP30	IP30	IP30	IP30	IP30
Dimensions (L x H x D) in mm	65 x 78 x 27	75 x 85 x 28	47 x 110 x 90	30 x 136 x 95	32 x 122 x 92
Supported Temperatures					
Operations Temperature	-40°C to +70°C	-20°C to +70°C	-10°C to +60°C	-30°C to +75°C	-40°C to +70°C
Storage Temperature	-40°C to +85°C	-40°C to +85°C	-40°C to +85°C	-40°C to +85°C	-40°C to +85°C
Modbus Features					
Modbus TCP/RTU/ASCII Gateway	•	•	•	•	•
Modbus TCP/RTU/ASCII Concentrator					
Redundancy option					
Exception error handling	•	•	•	•	•
VPN			•	•	•
Compliance					
Industrial EMC Protection	•	•	•	•	•
CE/FCC	•	•	•	•	•
UL/EN/IEC(CB)60950-1 and/or 62368-1			•		•
EN60950-1 and/or EN62368	•	•	•	•	•
UL61010-2-201					
IEC61850-3 / IEEE1613					

Modbus Gateways/ Modbus Concentrators

Advanced



General Information

Model Number	MB5901	MB5904D	MB5908	MB5916	MB5908A	MB5916A
Network Interfaces						
Total number of ports	2	2	2	2	6	6
Total Fast Ethernet	2	(2)*	2	2	6	6
10/100 BaseT(X)	2	(2)*	2	2	(6)*	(6)*
100 Base-X (SFP)	-	-	-	-	(6)*	(6)*
Total Gigabit	-	(2)*	-	-	-	-
10/100/1000 BaseT(X)	-	-	-	-	-	-
100/1000 Base-X SFP	-	(2)*	-	-	-	-
Wi-Fi interface	-	-	-	-	-	-
3G/4G interfaces	-	-	-	-	-	-
Network Redundancy						
RSTP redundant ports	2	2	2	2	2	2
Serial Ports						
Number of ports	1	4	8	16	8	16
RS-232 RS-422 RS-485 full func.	1	4	8	16	8	16
RS-232 only	-	-	-	-	-	-
Serial port Isolation	-	3kV(Optional)	2.5kV(Optional)	2.5kV(Optional)	3kV(Optional)	3kV(Optional)
Serial port connector	DSub9/TB	DSub9/TB	RJ45	RJ45	DSub9/TB	DSub9/TB
Other Interfaces						
Digital Inputs	-	-	-	-	-	-
Digital Outputs	-	-	-	-	-	-
Relay Output	-	1	1	1	1	1
Power Supply Input						
Power Input	9-48 VDC	12-48 VDC	24-48 VDC	24-48 VDC	24-48 VDC	24-48 VDC
Power PoE 802.3af (PD)	Optional	Optional				
AC power input			100-240 VAC	100-240 VAC	100-240 VAC	100-240 VAC
High Voltage DC power input					100-370 VDC	100-370 VDC
Power Redundancy		•			•	•
Mechanical						
Installation	DIN-Rail	DIN-Rail	Rack-mount	Rack-mount	Rack-mount	Rack-mount
Ingress Protection	IP30	IP30	IP30	IP30	IP30	IP30
Dimensions (L x H x D) in mm	32 x 122 x 92	55 x 145 x 113	440 x 44 x 200	440 x 44 x 200	440 x 44 x 309	440 x 44 x 309
Supported Temperatures						
Operations Temperature	-40°C to +85°C	-40°C to +85°C	-20°C to +70°C	-20°C to +70°C	-40°C to +85°C	-40°C to +85°C
Storage Temperature	-40°C to +85°C	-40°C to +85°C	-40°C to +85°C	-40°C to +85°C	-40°C to +85°C	-40°C to +85°C
Modbus Features						
Modbus TCP/RTU/ASCII Gateway	•	•	•	•	•	•
Modbus TCP/RTU/ASCII Concentrator	•	•	•	•	•	•
Redundancy option		•	•	•	•	•
Exception error handling	•	•	•	•	•	•
VPN	•	•	•	•	•	•
Compliance						
Industrial EMC Protection	•	•	•	•	•	•
CE/FCC	•	•	•	•	•	•
UL/EN/IEC(CB)60950-1 and/or 62368-1						
EN60950-1 and/or EN62368	•	•	•	•	•	•
UL61010-2-201		•				
IEC61850-3 / IEEE1613					•	•

*Numbers in parenthesis are options

Protocol Gateways for Smart-Grid and Substations

Substation retrofitting

Power utilities typically invest in the latest available technologies at the time of installation, but equipment in the grid system has a long lifespan, lasting over 50 years. As a result, both legacy and new technologies are present in the power grid.

The IEC 61850 standard, which allows devices from different manufacturers to work together with advanced communication capabilities, has quickly gained popularity around the world. The challenge, however, is to integrate all technologies seamlessly to enable this enhanced monitoring and control.

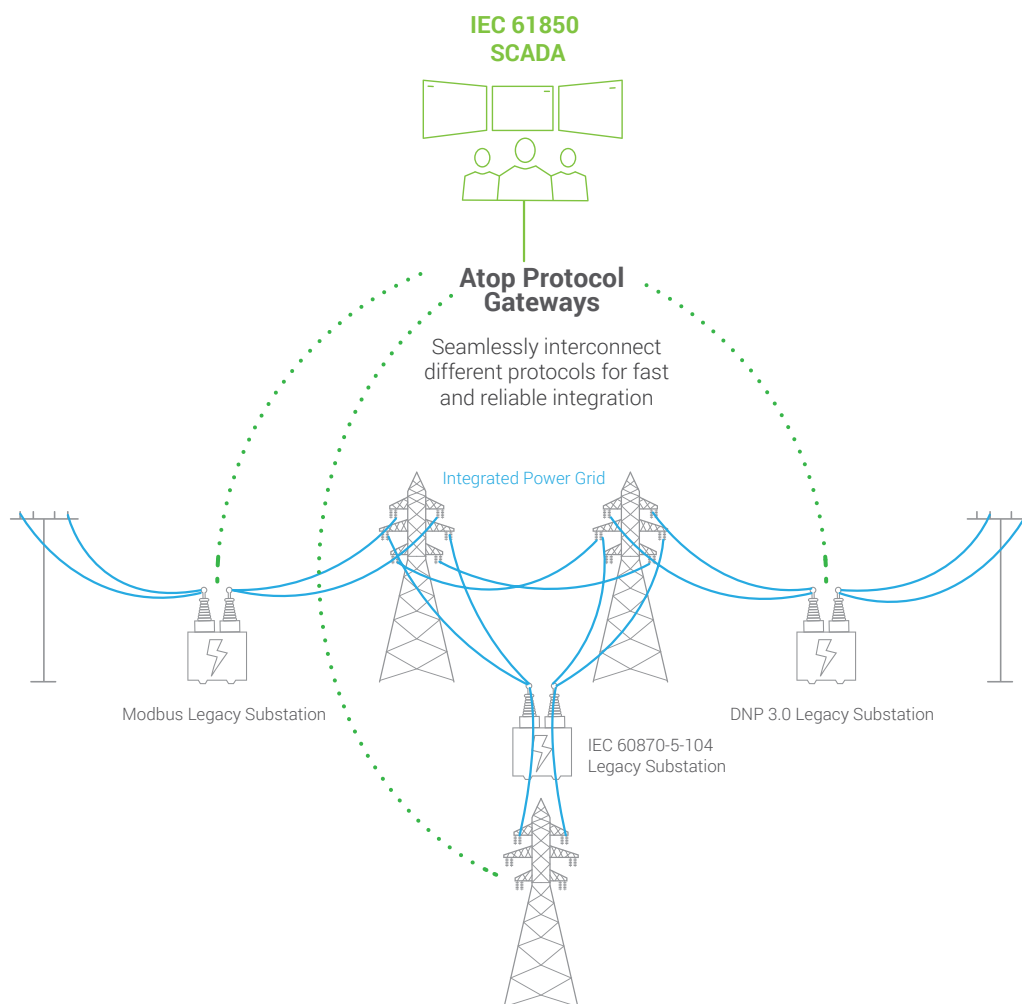

Integrating legacy protocols in the smart grid







Legacy substations operating with outdated or uncommon protocols can remain in place, thanks to ATOP's Protocol Gateways—powerful hardware platforms paired with stable software, that enable transparent, highly reliable, and fault-tolerant protocol-to-protocol translation.

ATOP's broad product range is designed to facilitate seamless integration with as much simplicity as possible. With over 80 different protocol combinations on 10 different hardware platforms, users can choose from hundreds of different products.

All products come with ATOP's user-friendly configuration tool that helps map data points quickly, allowing changeovers, upgrades, or integrations in a fast and cost-effective manner.

Protocol	Interface	Function
Modbus RTU	RS-485 ; RS-232 ; RS-422	Master/Slave
Modbus TCP	Ethernet	Client/Server
DNP 3.0 over Serial	RS-485 ; RS-232 ; RS-422	Master/Slave
DNP 3.0 over Ethernet	Ethernet	Client/Server
IEC 60870-5-101	RS-485 ; RS-232 ; RS-422	Master/Slave
IEC 60870-5-103	RS-485 ; RS-232 ; RS-422	Master/Slave
IEC 60870-5-104	Ethernet	Client/Server
IEC 61850	Ethernet	Client/Server

Hardware platforms

	Hardware	Mount	Ethernet Ports	RS-485 RS-232 RS-422 ports	Additional features
	PG5201B	Din-Rail	2 (RJ45)	1 (TB5 or DB9)	4G LTE or 3G connectivity
	PG5901	Din-Rail	2 (RJ45)	1 (TB5 or DB9)	can be PoE-powered [optional]
	PG5901B	Din-Rail	1 (RJ45)	1 (DB9 vers.) / 2 (TB14 I/O vers.)	4G LTE or 3G connectivity
	PG5904D-4P	Din-Rail	2 (RJ45 or SFP)	4 (TB5 or DB9)	can be PoE-powered [optional]
	PG5908	Rack-Mount	2 (RJ45)	8 (RJ45)	
	PG5916	Rack-Mount	2 (RJ45)	16 (RJ45)	
	PG5900A	Rack-Mount	6 (SFP or RJ45)		
	PG5908A	Rack-Mount	6 (SFP or RJ45)	8 (TB5 or DB9)	
	PG5916A	Rack-Mount	6 (SFP or RJ45)	16 (TB5 or DB9)	

Architecture concept

ATOP's family of Protocol Gateways are powerful industrial platforms that come bundled with different protocol stacks. Capable of running in Client-Server and Master/Slave modes simultaneously, their architecture consists of 3 parts:

- ① **Device Server/Slave interface:** Listens to a Client/Master outside the device, such as a PLC. The protocol gateway will act towards the external master as a slave device according to the protocol used.
- ② **Protocol engine:** The core of the unit that moves, translates, and maps the data points, commands, and events between the client and server sides.
- ③ **Device Client/Master interface:** Actively polls or issues commands to an external Server/Slave sides.

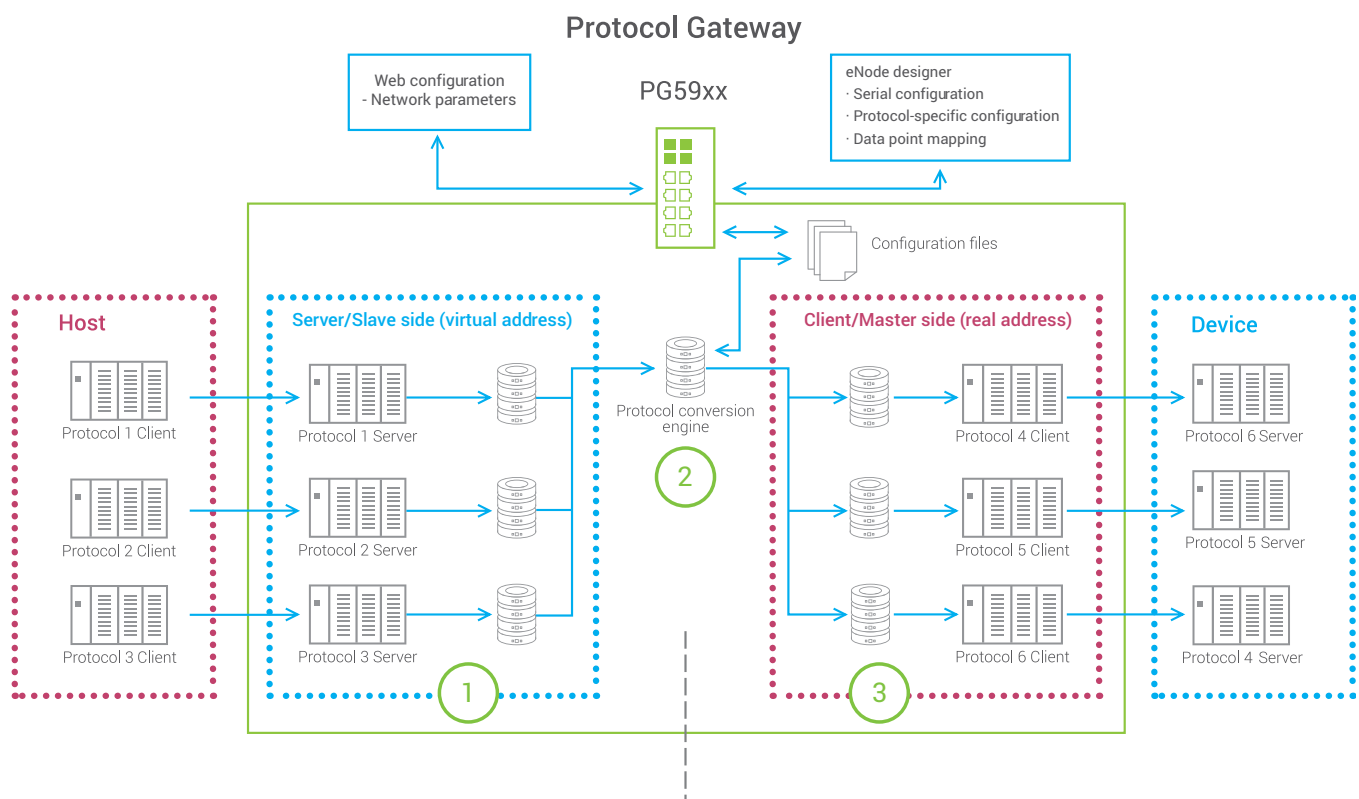

The core of the gateway is the protocol engine, in which data, commands, and events are stored and mapped to other protocols. Protocols can also be mapped to any Serial or Ethernet port. Using the eNode Designer tool, users can assign different protocols to different ports, configure serial port settings and protocol-specific parameters, and define real IDs or virtual addresses for the Master/Client or Slave/Server to work with, respectively.

Smart-Grid Protocol Gateways - Hardware



General Information

Coming soon

Model Number	PG5201B	PG5901	PG5901B	PG5904D	PG5908	PG5916	PG5900A	PG5908A	PG5916A
Interfaces									
Total number of ports	2	2	1	2	2	2	6	6	6
Total Fast Ethernet	2	2	-	(2)*	2	2	6	6	6
10/100 BaseT(X)*	2	2	-	(2)*	2	2	(6)*	(6)*	(6)*
100 Base-X (SFP)	-	-	-	-	-	-	(6)*	(6)*	(6)*
Total Gigabit	-	-	1	(2)*	-	-	-	-	-
10/100/1000 BaseT(X)	-	-	1	-	-	-	-	-	-
100/1000 Base-X SFP	-	-	-	(2)*	-	-	-	-	-
1000Base-X SFP	-	-	-	-	-	-	-	-	-
4G interfaces	Cat 1	-	Cat 4	-	-	-	-	-	-
Network Redundancy									
RSTP redundant ports	-	2	-	2	2	2	6	6	6
HSR/PRP redundant ports	-	-	-	-	-	-	-	-	-
Serial Ports									
Number of ports	1	1	1/2 (IO vers)	4	8	16	-	8	16
RS-232 RS-422 RS-485 full func.	1	1	1 (RS-232/485)	4	8	16	-	8	16
RS-232 only	-	-	1 (only IO vers)	-	-	-	-	-	-
Serial port Isolation	-	-	-	3kV Optional	2.5kV Optional	2.5kV Optional	-	3kV Optional	3kV Optional
Terminal Block (TB) ports	(1)*	(1)*	(1)*	(4)*	-	-	-	(8)*	(16)*
D-Sub 9 (DB9) ports	(1)*	(1)*	(1)*	(4)*	-	-	-	(8)*	(16)*
RJ45 Serial ports	-	-	-	-	8	16	-	-	-
Other Interfaces									
Digital Inputs	1	-	2 (Optional)	-	-	-	-	-	-
Digital Outputs	1	-	2 (Optional)	-	-	-	-	-	-
Power Supply Input									
Low Voltage DC power Input	9-48 VDC	9-48 VDC	9-48 VDC	12-48 VDC	24-48 VDC	24-48 VDC	24-48 VDC	24-48 VDC	24-48 VDC
Power through PoE 802.3af		Optional		Optional					
AC power input					100-240 VAC	100-240 VAC	100-240 VAC	100-240VAC	100-240VAC
High Voltage DC power input							100-370 VDC	100-370 VDC	100-370 VDC
Power Inputs	1	1	1	2	1	1	2	2	2
Relay Output	1			2			2	2	2
Installation									
Mount	DIN-Rail	DIN-Rail	DIN-Rail	DIN-Rail	Rack-Mount	Rack-Mount	Rack-Mount	Rack-Mount	Rack-Mount
Ingress Protection	IP30	IP30	IP30	IP30	IP30	IP30	IP30	IP30	IP30
Environment									
Operational Temperature	-30 to +75°C	-40°C to +85°C	-40°C to +75°C	-40°C to +85°C	-20°C to +70°C	-20°C to +70°C	-40°C to +85°C	-40°C to +85°C	-40°C to +85°C
Compliance									
Industrial EMC Protection	•	•	•	•	•	•	•	•	•
UL60950-1									
UL61010-2-201				•			EN	EN	EN
EN60950-1	•	•	•		•	•			
CE (EN61000-6-2 and EN61000-6-4)	•	•	•	•	•	•	•	•	•
RED (Radio Directive 2014/53/EU)	•	n/a	•	n/a	n/a	n/a	n/a	n/a	n/a
FCC Part 15 Subpart B Class A	•	•	•	•	•	•	•	•	•
IEC61850-3 / IEEE1613							•	•	•

*Numbers in parenthesis are options

Smart-Grid Protocol Gateways - Software



General Information

Model Number	PG5201B	PG5901	PG5901B	PG5904D	PG5908	PG5916	PG5900A	PG5908A	PG5916A
--------------	---------	--------	---------	---------	--------	--------	---------	---------	---------

Protocol Gateway Software Model Number / Availability

Front-End Protocol	Back-End Protocol	SKU								
Modbus RTU/ ASCII Slave	DNP3.0 Master				MBSS-DNSM	MBSS-DNSM	MBSS-DNSM		MBSS-DNSM	MBSS-DNSM
	DNP3.0 Client	MBSS-DNEC	MBSS-DNEC	MBSS-DNEC	MBSS-DNEC	MBSS-DNEC	MBSS-DNEC		MBSS-DNEC	MBSS-DNEC
	IEC 101 Master				MBSS-01SM	MBSS-01SM	MBSS-01SM		MBSS-01SM	MBSS-01SM
	IEC 103 Master				MBSS-03SM	MBSS-03SM	MBSS-03SM		MBSS-03SM	MBSS-03SM
	IEC 104 Client	MBSS-04EC	MBSS-04EC	MBSS-04EC	MBSS-04EC	MBSS-04EC	MBSS-04EC		MBSS-04EC	MBSS-04EC
	IEC 61850 Client	MBSS-50EC	MBSS-50EC	MBSS-50EC	MBSS-50EC	MBSS-50EC	MBSS-50EC		MBSS-50EC	MBSS-50EC
Modbus TCP Server	DNP3.0 Master	MBES-DNSM	MBES-DNSM	MBES-DNSM	MBES-DNSM	MBES-DNSM	MBES-DNSM		MBES-DNSM	MBES-DNSM
	DNP3.0 Client	MBES-DNEC	MBES-DNEC	MBES-DNEC	MBES-DNEC	MBES-DNEC	MBES-DNEC	MBES-DNEC	MBES-DNEC	MBES-DNEC
	IEC 101 Master	MBES-01SM	MBES-01SM	MBES-01SM	MBES-01SM	MBES-01SM	MBES-01SM		MBES-01SM	MBES-01SM
	IEC 103 Master	MBES-03SM	MBES-03SM	MBES-03SM	MBES-03SM	MBES-03SM	MBES-03SM		MBES-03SM	MBES-03SM
	IEC 104 Client	MBES-04EC	MBES-04EC	MBES-04EC	MBES-04EC	MBES-04EC	MBES-04EC	MBES-04EC	MBES-04EC	MBES-04EC
	IEC 61850 Client	MBES-50EC	MBES-50EC	MBES-50EC	MBES-50EC	MBES-50EC	MBES-50EC	MBES-50EC	MBES-50EC	MBES-50EC
DNP3.0 Serial Slave	Modbus Master				DNSS-MBSM	DNSS-MBSM	DNSS-MBSM		DNSS-MBSM	DNSS-MBSM
	Modbus Client	DNSS-MBEC	DNSS-MBEC	DNSS-MBEC	DNSS-MBEC	DNSS-MBEC	DNSS-MBEC		DNSS-MBEC	DNSS-MBEC
	DNP3.0 Master				DNSS-DNSM	DNSS-DNSM	DNSS-DNSM		DNSS-DNSM	DNSS-DNSM
	DNP3.0 Client	DNSS-DNEC	DNSS-DNEC	DNSS-DNEC	DNSS-DNEC	DNSS-DNEC	DNSS-DNEC		DNSS-DNEC	DNSS-DNEC
	IEC 101 Master				DNSS-01SM	DNSS-01SM	DNSS-01SM		DNSS-01SM	DNSS-01SM
	IEC 103 Master				DNSS-03SM	DNSS-03SM	DNSS-03SM		DNSS-03SM	DNSS-03SM
	IEC 104 Client	DNSS-04EC	DNSS-04EC	DNSS-04EC	DNSS-04EC	DNSS-04EC	DNSS-04EC		DNSS-04EC	DNSS-04EC
	IEC 61850 Client	DNSS-50EC	DNSS-50EC	DNSS-50EC	DNSS-50EC	DNSS-50EC	DNSS-50EC		DNSS-50EC	DNSS-50EC
DNP3.0 TCP/IP Server	Modbus Master	DNES-MBSM	DNES-MBSM	DNES-MBSM	DNES-MBSM	DNES-MBSM	DNES-MBSM		DNES-MBSM	DNES-MBSM
	Modbus Client	DNES-MBEC	DNES-MBEC	DNES-MBEC	DNES-MBEC	DNES-MBEC	DNES-MBEC	DNES-MBEC	DNES-MBEC	DNES-MBEC
	DNP3.0 Client	DNES-DNSM	DNES-DNSM	DNES-DNSM	DNES-DNSM	DNES-DNSM	DNES-DNSM		DNES-DNSM	DNES-DNSM
	IEC 101 Master	DNES-01SM	DNES-01SM	DNES-01SM	DNES-01SM	DNES-01SM	DNES-01SM		DNES-01SM	DNES-01SM
	IEC 103 Master	DNES-03SM	DNES-03SM	DNES-03SM	DNES-03SM	DNES-03SM	DNES-03SM		DNES-03SM	DNES-03SM
	IEC 104 Client	DNES-04EC	DNES-04EC	DNES-04EC	DNES-04EC	DNES-04EC	DNES-04EC	DNES-04EC	DNES-04EC	DNES-04EC
	IEC 61850 Client	DNES-50EC	DNES-50EC	DNES-50EC	DNES-50EC	DNES-50EC	DNES-50EC	DNES-50EC	DNES-50EC	DNES-50EC
IEC60870-5-101 Slave	Modbus Master				01SS-MBSM	01SS-MBSM	01SS-MBSM		01SS-MBSM	01SS-MBSM
	DNP3.0 Master				01SS-DNSM	01SS-DNSM	01SS-DNSM		01SS-DNSM	01SS-DNSM
	IEC 103 Master				01SS-03SM	01SS-03SM	01SS-03SM		01SS-03SM	01SS-03SM
IEC60870-5-104 Server	Modbus Master	04ES-MBSM	04ES-MBSM	04ES-MBSM	04ES-MBSM	04ES-MBSM	04ES-MBSM		04ES-MBSM	04ES-MBSM
	Modbus Client	04ES-MBEC	04ES-MBEC	04ES-MBEC	04ES-MBEC	04ES-MBEC	04ES-MBEC	04ES-MBEC	04ES-MBEC	04ES-MBEC
	DNP3.0 Master	04ES-DNSM	04ES-DNSM	04ES-DNSM	04ES-DNSM	04ES-DNSM	04ES-DNSM		04ES-DNSM	04ES-DNSM
	DNP3.0 Client	04ES-DNEC	04ES-DNEC	04ES-DNEC	04ES-DNEC	04ES-DNEC	04ES-DNEC	04ES-DNEC	04ES-DNEC	04ES-DNEC
	IEC 101 Master	04ES-01SM	04ES-01SM	04ES-01SM	04ES-01SM	04ES-01SM	04ES-01SM		04ES-01SM	04ES-01SM
	IEC 103 Master	04ES-03SM	04ES-03SM	04ES-03SM	04ES-03SM	04ES-03SM	04ES-03SM		04ES-03SM	04ES-03SM
	IEC 61850 Client	04ES-50EC	04ES-50EC	04ES-50EC	04ES-50EC	04ES-50EC	04ES-50EC	04ES-50EC	04ES-50EC	04ES-50EC
IEC61850 Server	Modbus Master	50ES-MBSM	50ES-MBSM	50ES-MBSM	50ES-MBSM	50ES-MBSM	50ES-MBSM		50ES-MBSM	50ES-MBSM
	Modbus Client	50ES-MBEC	50ES-MBEC	50ES-MBEC	50ES-MBEC	50ES-MBEC	50ES-MBEC	50ES-MBEC	50ES-MBEC	50ES-MBEC
	DNP3.0 Master	50ES-DNSM	50ES-DNSM	50ES-DNSM	50ES-DNSM	50ES-DNSM	50ES-DNSM	50ES-DNSM	50ES-DNSM	50ES-DNSM
	DNP3.0 Client	50ES-DNEC	50ES-DNEC	50ES-DNEC	50ES-DNEC	50ES-DNEC	50ES-DNEC	50ES-DNEC	50ES-DNEC	50ES-DNEC
	IEC 101 Master	50ES-01SM	50ES-01SM	50ES-01SM	50ES-01SM	50ES-01SM	50ES-01SM		50ES-01SM	50ES-01SM
	IEC 103 Master	50ES-03SM	50ES-03SM	50ES-03SM	50ES-03SM	50ES-03SM	50ES-03SM		50ES-03SM	50ES-03SM
	IEC 104 Client	50ES-04EC	50ES-04EC	50ES-04EC	50ES-04EC	50ES-04EC	50ES-04EC	50ES-04EC	50ES-04EC	50ES-04EC

Appendix : Protocol Specifications

IEC61850 Server/ Client	
Supported Functions (Read, Write)	<ul style="list-style-type: none"> • Generic access to the data (Read, Write) • Clock Synchronization • 8 Logical Devices per Port
Supported Control Type of commands	<ul style="list-style-type: none"> • Direct-with-Normal-Security • Select Before Operate (SBO)-with-Normal-Security • Direct-with-Enhanced Security Select Before Operate (SBO)-with-Enhanced-Security
Implemented Protocol Subsets	<ul style="list-style-type: none"> • IEC 61850-6 (Substation Configuration Language Description: SCL) • IEC 61850-7-1 (Principles and Models) • IEC 61850-7-2 (Abstract Communication Service Interface: ACSI) • IEC 61850-7-3 (Common Data Classes: CDC) • IEC 61850-7-4 (Logical Nodes and data Object Classes) • IEC 61850-8-1 (Mapping to Manufacturing Message Specification: MMS) • Edition 1 & Edition 2 are both Supported
DNP3 Server/ Client/ Master/ Slave	
Support Level	Level 2 and subset of Level 3
General Specifications	<ul style="list-style-type: none"> • Serial Mode or Ethernet with TCP or UDP Mode • Server side supports serving up to 5 client in TCP Mode • Client side in a single RS-485 port, supports connecting up to 16 IEDs • Client side supports connecting up to 16 IEDs • Maximum Fragment size 2048 octets • Protocol implementation with configurable parameters conforms to IEEE Std 1815-2012 level 2
Supported Functions	<ul style="list-style-type: none"> • Time Synchronization generic access to the data(Read, Write) • Commands with or without preselection (Select, Operate, Direct Operate) • Transmission of time-tagged events • Counter management (Immediate Freeze, Freeze and Clear) • Self-address
Supported DNP3 Object Library	<ul style="list-style-type: none"> • Binary Inputs up to 8000 pts • Binary Outputs up to 2000 pts • Double Inputs up to 4000 pts • Analog Inputs up to 250 pts • Analog Outputs up to 250 pts • Counters up to 250 pts
Modbus Server/ Client/ Master/ Slave	
General Specifications	<ul style="list-style-type: none"> • Support Modbus RTU and ASCII in Serial mode • Support Modbus in TCP mode • For Modbus devices, support connecting up to 64 Modbus slaves/servers - client/masters • Support maximum number of data points in read direction: 8000 pts • Support maximum number of commands in write direction: 4000 pts
Supported Function Codes	<ul style="list-style-type: none"> 1: Read Coils 2: Read Discrete Inputs 3: Read Holding Registers 4: Read Input Registers 5: Write Single Coil 6: Write Single Register 15: Write Multiple Coils 16: Write Multiple Registers 43: Read Device Identification (server side only)
Supported Exception Codes	<ul style="list-style-type: none"> 1: Illegal function 2: Illegal data address 3: Illegal data value 4: Server device failure 6: Server device busy

IEC 60870-5-101 Master/ Slave

General Specifications	<ul style="list-style-type: none"> • Protocol implementation with configurable parameters conforms to the IEC 60870-5-101 edition 2 specification • Process Information in Monitor and Control Direction • Balanced and Unbalanced Modes • CP24Time2a or CP56Time2a timestamp for monitor direction report
Supported Functions	<ul style="list-style-type: none"> • Station Initialization • Interrogation • Read Procedure • Cyclic Data and Spontaneous Transmission (Slave Side only) • Clock Synchronization • Transmission of Integrated Totals • Direct and SBO command
Supported Data Types	<ul style="list-style-type: none"> • Monitors Points: Each supports up to 1000 pts: Single Point, Double Point, Step Position, Bit String, Measured with Normalized Value, Measured with Scaled Value, Measured Short Floating Point Value, Integrated Totals • Control Points: Each supports up to 500 pts: Single Command, Double Command, Regulating Step Command, Set Point Command with Normalized Value, Set Point Command with Scaled Value, Set Point Command Short Floating Point, Bit string

IEC 60870-5-103 Master

General Specifications	<ul style="list-style-type: none"> • Protocol implementation with configurable parameters conforms to the IEC 60870-5-103:1997 • Master supports connecting up to 16 IEDs • Process Information in Monitor and Control Direction • Unbalanced Modes
Supported Functions	<ul style="list-style-type: none"> • Station Initialization, Supports reset FCB and CU • General Interrogation • Clock Synchronization • Command Transmission • Test Mode • Blocking of Monitor Direction
Supported Data Types	<ul style="list-style-type: none"> • Monitor direction: <ul style="list-style-type: none"> * Status indications in monitor direction: from <16> to <30> * Supervision indications in monitor direction: <32>, <33>, from <35> to <39>, <46>, <47> * Earth fault indications in monitor direction: from <48> to <52> * Fault indications in monitor direction: from <64> to <93> * Auto-reclosure indications in monitor direction: from <128> to <130> * Measurands in monitor direction: from <144> to <148> • Control direction: <ul style="list-style-type: none"> * General commands in control direction: from <16> to <19>, from <23> to <26>

IEC 60870-5-104 Server/ Client

General Specifications	<ul style="list-style-type: none"> • Server side supports serving up to 5 client • Client side supports connecting up to 10 IEDs • Protocol implementation with configurable parameters conforms to the IEC 60870-5-104 specification edition 2 • Process Information in Monitor and Control Direction • CP56Time2a timestamp for Control Commands
Supported Functions	<ul style="list-style-type: none"> • Station Initialization • Interrogation • Read Procedure • Cyclic Data and Spontaneous Transmission (Slave Side only) • Clock Synchronization • Transmission of Integrated Totals • Direct and SBO command
Supported Data Types	<ul style="list-style-type: none"> • Monitors Points: Each supports maximum 1000 pts: Single Point, Double Point, Step Position, Bit String, Measured with Normalized Value, Measured with Scaled Value, Measured Short Floating Points Value, Integrated Totals. • Control Points: Each supports maximum 500 pts: Single Command, Double Command, Regulating Step Command, Set Point Command with Normalized Value, Set Point Command with Scaled Value, Set Point Command Short Floating Point, Bitstring. • Event Logging (Server Side only) Universal Event Buffer up to 20,000 Events



Pericom AG

Moskau 314B CH 8262 Ramsen t 052 740 00 55

Waldstr. 7 D 78262 Gailingen t 07734 48 70 343

www.pericom.biz

info@pericom.biz

